

# STARLINE® S-2 (900-0020)

## Parts List - diagram

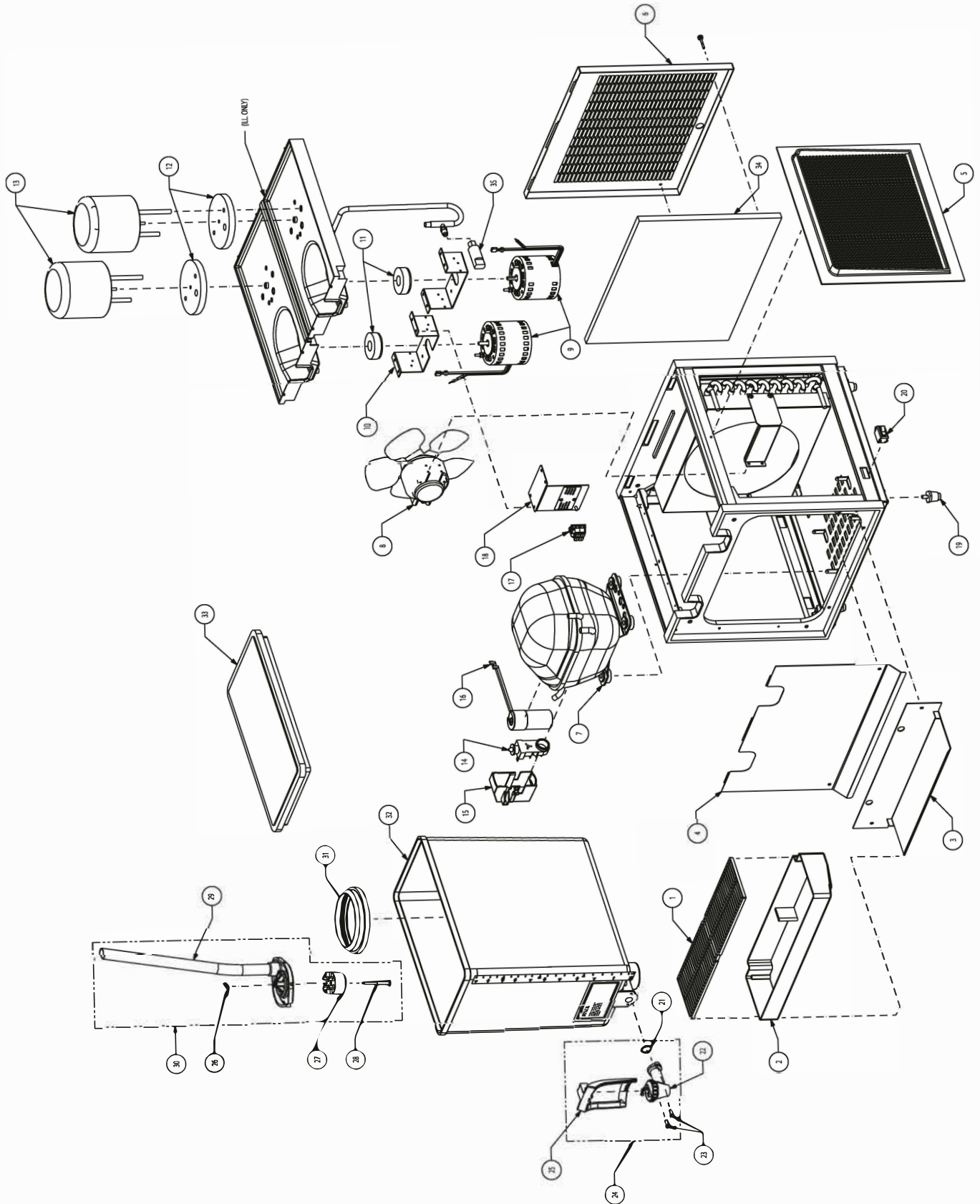

# STARLINE® S-2 (900-0020)

## Parts List - part numbers

ITEM	PART NUMBER	DESCRIPTION
1	265-0057	CUP REST
2	265-0222	DRIP TRAY
3	319-0011	DRIP TRAY PANEL
4	319-0174	FRONT PANEL
5	265-0337	GRILL, SIDE
6	265-0552	PANEL, REAR
7	300-0002	COMPRESSOR
8	304-0005	FAN MOTOR
9	304-0001	PUMP MOTOR
10	319-0177	PUMP MTG BRACKET
11	645-0009	IMPELLER DRIVE ASSY W /SET SCREW
12	210-0002	GASKET, EVAPORATOR
13	645-0028	EVAP. DOME ASSYW/THERMOWELL
14	507-0009	RELAY /OVERLOAD
15	631-0014	COVER
16	507-0008	START CAP
17	506-0015	TERMINAL BLOCK ASSY
18	319-0184	BRACKET, TERMINAL BLOCK
19	234-0003	LEG, LEVELLER
20	505-0001	SPRAY/REF. SWITCH
21	208-1115	O-RING, FAUCET
22	637-0001	FAUCET BODY ASSY
23	220-0008	SCREW, FAUCET MTG
24	645-0005	3" FAUCET ASSY
25	631-0007	PUSH HANDLE ASSEMBLY
26	247-0001	HITCH PIN
27	645-0002	IMPELLER ASSY
28	279-0006	IMPELLER SHAFT
29	631-0005	SPRAY TUBE/KNOB
30	631-0006	SPRAY TUBE/IMPELLER ASSY
31	210-0004	BOWL GASKET
32	631-0008	BOWL ASSY
33	265-0050	BOWL COVER
34	286-0004	FILTER
35	505-0024	CONTROL, LOW PRESSURE