

MODEL: WB-CD-1-3-SS-RCT

1 PRODUCT STAINLESS STEEL CONDIMENT
REMOTE COUNTERTOP TOWER:
WITH 3-GALLON BAG HOLDER



PRODUCT SPECIFICATIONS:

CAPACITY: ONE 3-GALLON BAG-IN-BOX
DIMENSIONS: 3-3/8" WIDE X 8-3/4" DEEP X 12-3/4" HIGH
WEIGHT: 10 LBS. (EMPTY)

ONE BAG-IN-BOX CONNECTOR INCLUDED PER PRODUCT
-CPC 95400 (FOR 38mm BIB)

SYSTEM FEATURES:

- IN PLACE CLEANABLE
- STAINLESS STEEL CONSTRUCTION
- 3 GALLON PRODUCT HOLDER BELOW COUNTER
- COMPACT TOWER WITH DRIP PAN
- NO ELECTRICITY OR PROPELLANT REQUIRED
- 3/4 OZ NOMINAL POUR SIZE PER FULL PUMP STROKE

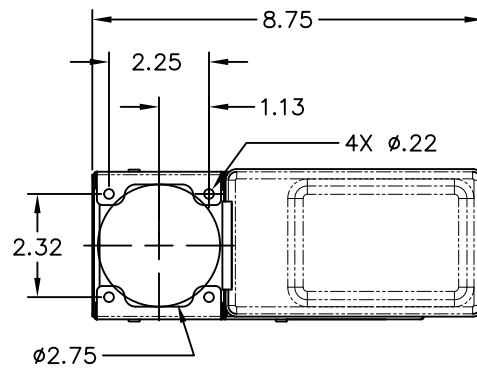
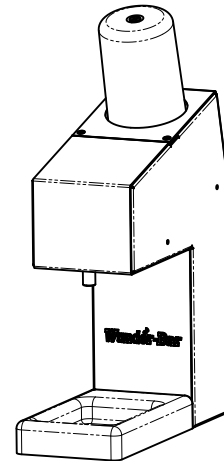

MOUNTING DETAIL:

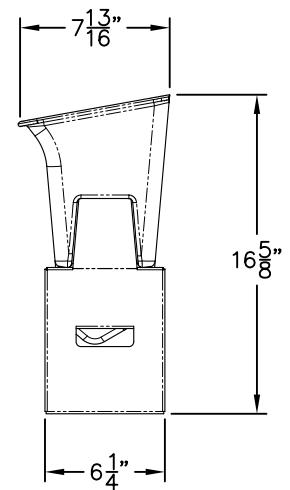
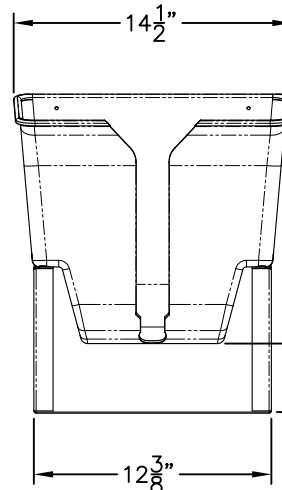
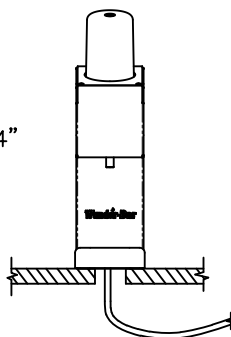
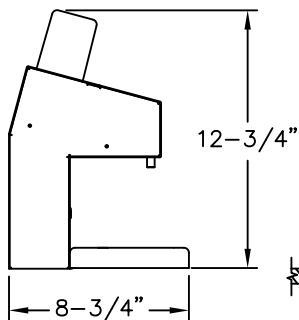
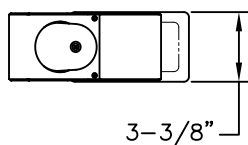

3 GALLON BAG HOLDER

0150244D.DWG / 28 JUL 2017

Wunder-Bar™

AUTOMATIC BAR CONTROLS, INC.
2060 CESSNA DR, SUITE 100
VACAVILLE, CA 95688

www.wunderbar.com

PHONE: (707) 448-5151
FAX : (707) 448-1521