

MODEL: WB-SCD-2-4-TT
CONDIMENT SYSTEM: 2 STATION WITH FOUR
PRODUCT T-TOWERS

JOB:

ITEM#:



PRODUCT RACK SPECIFICATIONS:

CONSTRUCTION: FORMED ACRYLONITRILE BUTADIENE
 STYRENE (A.B.S.) 100# CAPACITY
 EXTRA-HEAVY-DUTY TRAY SLIDES.

CAPACITY: FOUR, THREE-GALLON CONDIMENT
 BAGS, FOUR CONDIMENT PUMPS,
 FOUR 100 PSI LOW PRESSURE REGULATOR.

DIMENSIONS: 19" WIDE X 26" DEEP X 19" HIGH.

INSTALLATION: MINIMUM CABINET REQUIREMENTS
 29" DEEP X 27" WIDE X 26" HIGH.

WEIGHT: 65# (EMPTY)

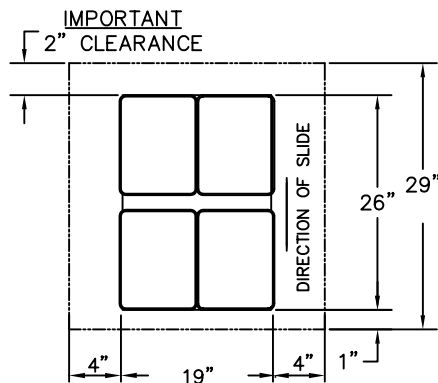
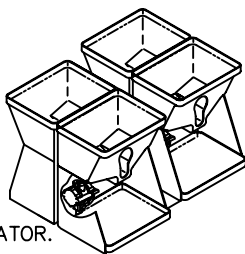

CABINET TOP VIEW

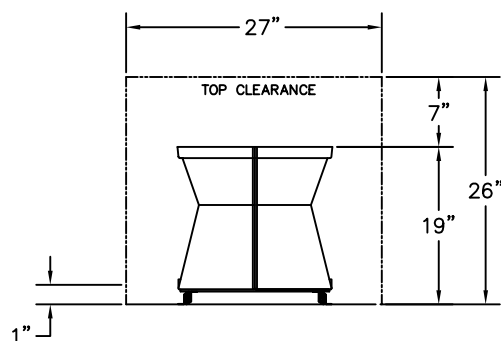

CABINET FRONT VIEW

SYSTEM FEATURES:

- FULLY FACTORY ASSEMBLED AND WET-CHECKED
 NON-PORTION CONTROL CONDIMENT T-TOWER
 SIMPLE CONNECTION OF SYSTEM TO TOWER
 DISPENSER TO COMPLETE FINIAL INSTALLATION.
- BUILT-IN CONDIMENT SPILL CONTAINMENT RIM AROUND RACK BASES.
- RACK FULLY EXTENDS FOR EASY RE-LOADING OF BAGS.
- 8' OF 1/4" I.D. PRODUCT TUBING PROVIDED FOR KETCHUP,
 MUSTARD OR SAUCE. 8' OF 3/8" ID PRODUCT TUBING PROVIDED
 FOR MAYONNAISE. PLEASE SPECIFY PRODUCTS WHEN ORDERING.
- ONE, FOUR-PRODUCT T-TOWER CONDIMENT DISPENSER.
 ALL MOUNTING HARDWARE INCLUDED.
- BRUSHED STAINLESS STEEL TOWER

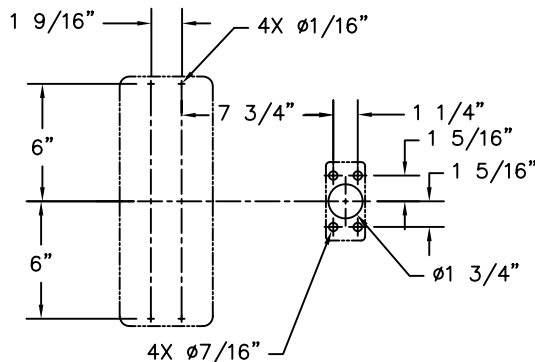
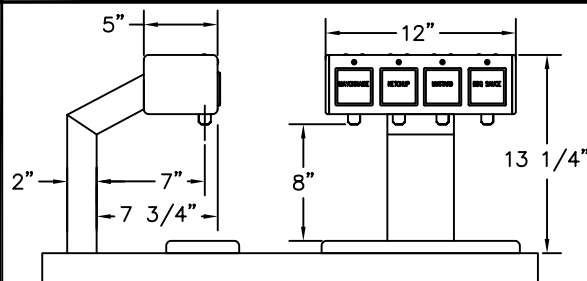
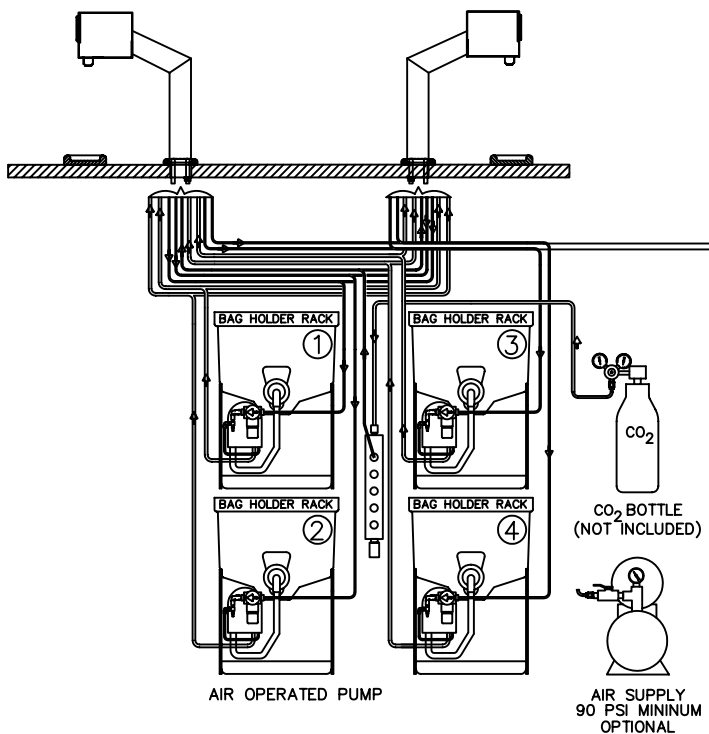

T-TOWER & MOUNTING DETAIL

Z:\01\0150112C.DWG / 12-22-04

Wunder - Bar Dispensing Systems

AUTOMATIC BAR CONTROLS, INC.
 790 EUBANKS DRIVE
 VACAVILLE, CA 95688

PHONE: (707) 448-5151
FAX : (707) 448-1521