

MODEL: WB-CD-2-1-MT

CONDIMENT SYSTEM: 2 STATION WITH ONE PRODUCT MINI TOWER DISPENSER

JOB:

ITEM#:



PRODUCT RACK SPECIFICATIONS:

CONSTRUCTION: VACUUM FORMED ACRYLONITRILE BUTADIENE STYRENE (A.B.S.) 100# CAPACITY EXTRA-HEAVY-DUTY TRAY SLIDES.

CAPACITY: ONE, THREE-GALLON CONDIMENT BAG, ONE CONDIMENT PUMP, ONE 100# LOW PRESSURE REGULATOR.

DIMENSIONS: 9 3/8" WIDE X 12 1/8" DEEP X 19" HIGH.

INSTALLATION: MINIMUM CABINET REQUIREMENTS 16 1/8" DEEP X 11 1/8" WIDE X 23" HIGH.

WEIGHT: 35# (EMPTY)

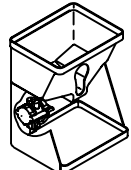

SYSTEM FEATURES:

- FULLY FACTORY ASSEMBLED AND WET-CHECKED, NON-PORTION CONTROL CONDIMENT MINI TOWER. SIMPLE CONNECTION OF SYSTEM TO TOWER DISPENSER TO COMPLETE FINAL INSTALLATION.
- BUILT-IN CONDIMENT SPILL CONTAINMENT RIM AROUND PERIMETER OF BASE.
- RACK FULLY EXTENDS FOR EASY RE-LOADING OF BAGS.
- 8' OF 1/4" I.D. PRODUCT TUBING PROVIDED PER CONDIMENT FOR KETCHUP, MUSTARD OR SAUCE. 8' OF 3/8" ID PRODUCT TUBING PROVIDED FOR MAYONNAISE. PLEASE SPECIFY PRODUCTS.
- EXCLUSIVE PASSIVE DRAWBACK VALVE PREVENTS CONDIMENT DRIP BETWEEN DISPENSES. ONE PASSIVE DRAWBACK VALVE INCLUDED PER CONDIMENT PRODUCT
- TWO ONE PRODUCT MINI TOWER CONDIMENT DISPENSERS. ALL MOUNTING HARDWARE INCLUDED.

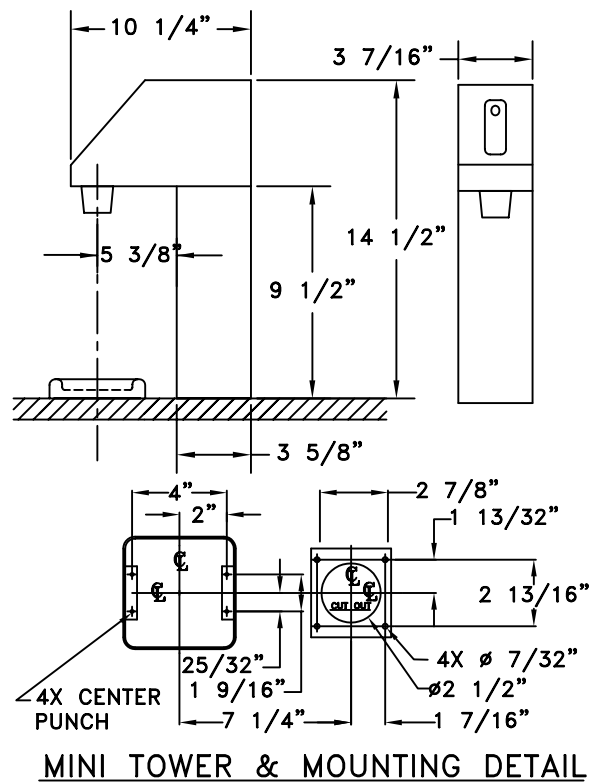
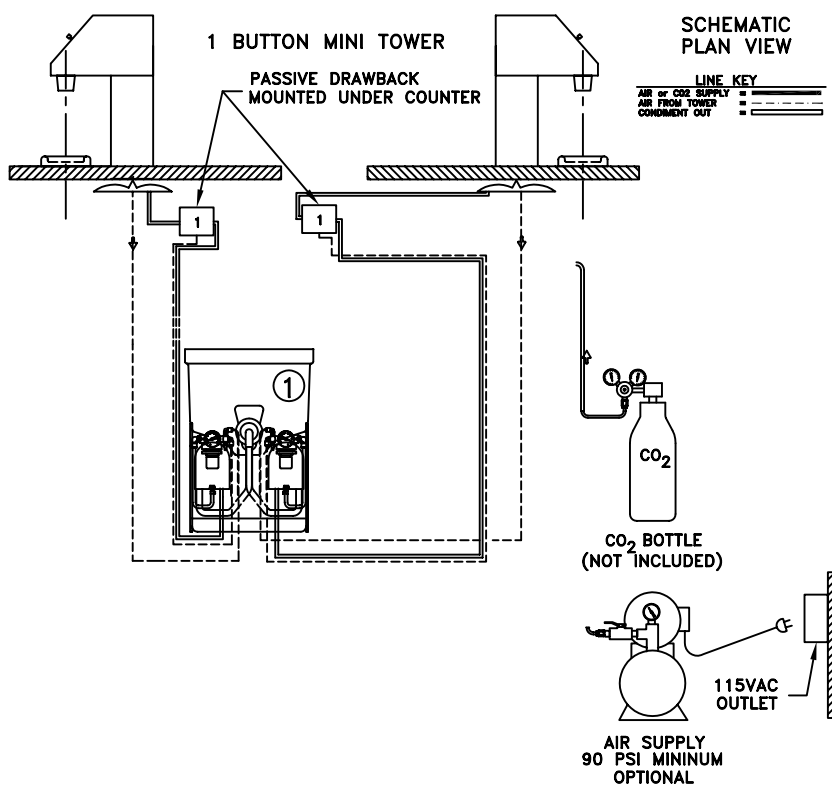
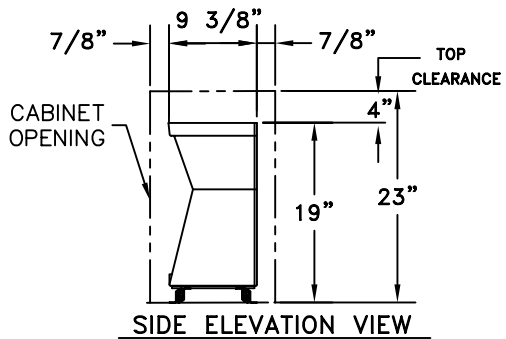
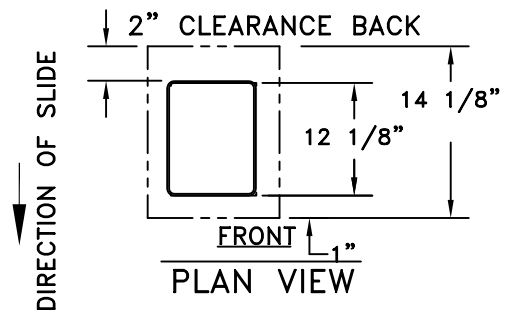

Z:\01\0150025.DWG / 4-20-2004

Wunder - Bar Dispensing Systems

AUTOMATIC BAR CONTROLS, INC.
790 EUBANKS DRIVE
VACAVILLE, CA 95688

PHONE: (707) 448-5151
FAX : (707) 448-1521