

MODEL: **WB-CD-1-1-MT**

CONDIMENT SYSTEM: 1 STATION WITH ONE PRODUCT MINI TOWER DISPENSER

JOB:

ITEM#:



**PRODUCT RACK SPECIFICATIONS:**

**CONSTRUCTION:** VACUUM FORMED ACRYLONITRILE BUTADIENE STYRENE (A.B.S.) 100# CAPACITY EXTRA-HEAVY-DUTY TRAY SLIDES.

**CAPACITY:** ONE, THREE-GALLON CONDIMENT BAG, ONE CONDIMENT PUMP, ONE 100# LOW PRESSURE REGULATOR.

**DIMENSIONS:** 9 3/8" WIDE X 12 1/8" DEEP X 19" HIGH.

**INSTALLATION:** MINIMUM CABINET REQUIREMENTS 16 1/8" DEEP X 11 1/8" WIDE X 23" HIGH.

**WEIGHT:** 35# (EMPTY)

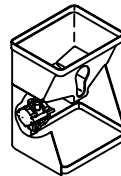

**SYSTEM FEATURES:**

- FULLY FACTORY ASSEMBLED AND WET-CHECKED NON-PORTION CONTROL CONDIMENT MINI TOWER. SIMPLE CONNECTION OF SYSTEM TO TOWER DISPENSER TO COMPLETE FINAL INSTALLATION.
- BUILT-IN CONDIMENT SPILL CONTAINMENT RIM AROUND PERIMETER OF BASE.
- RACK FULLY EXTENDS FOR EASY RE-LOADING OF BAGS.
- 8' OF 1/4" I.D. PRODUCT TUBING PROVIDED PER CONDIMENT FOR KETCHUP, MUSTARD OR SAUCE. 8' OF 3/8" ID PRODUCT TUBING PROVIDED FOR MAYONNAISE. PLEASE SPECIFY PRODUCTS WHEN ORDERING.
- EXCLUSIVE PASSIVE DRAWBACK VALVE PREVENTS CONDIMENT DRIP BETWEEN DISPENSES. ONE PASSIVE DRAWBACK VALVE INCLUDED PER CONDIMENT PRODUCT.
- ONE PRODUCT MINI TOWER CONDIMENT DISPENSER. ALL MOUNTING HARDWARE INCLUDED.

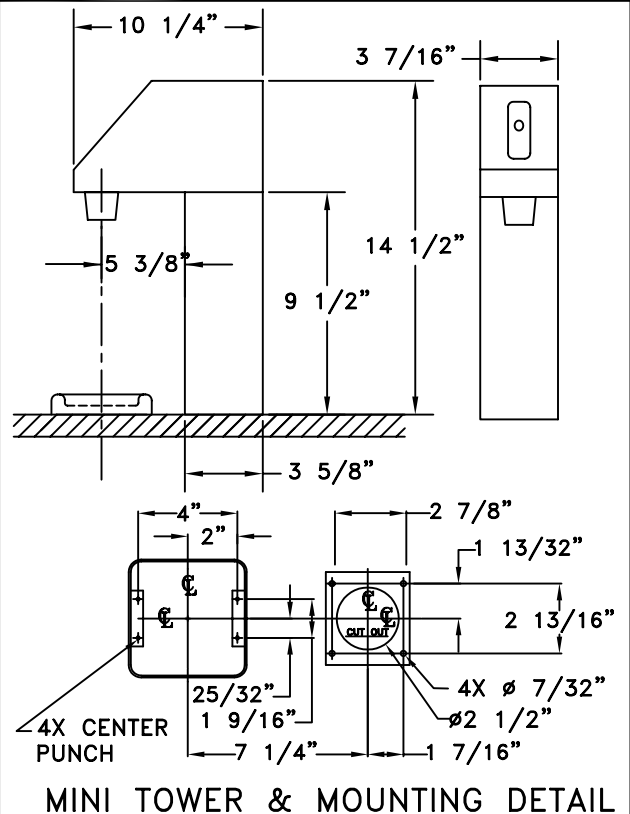
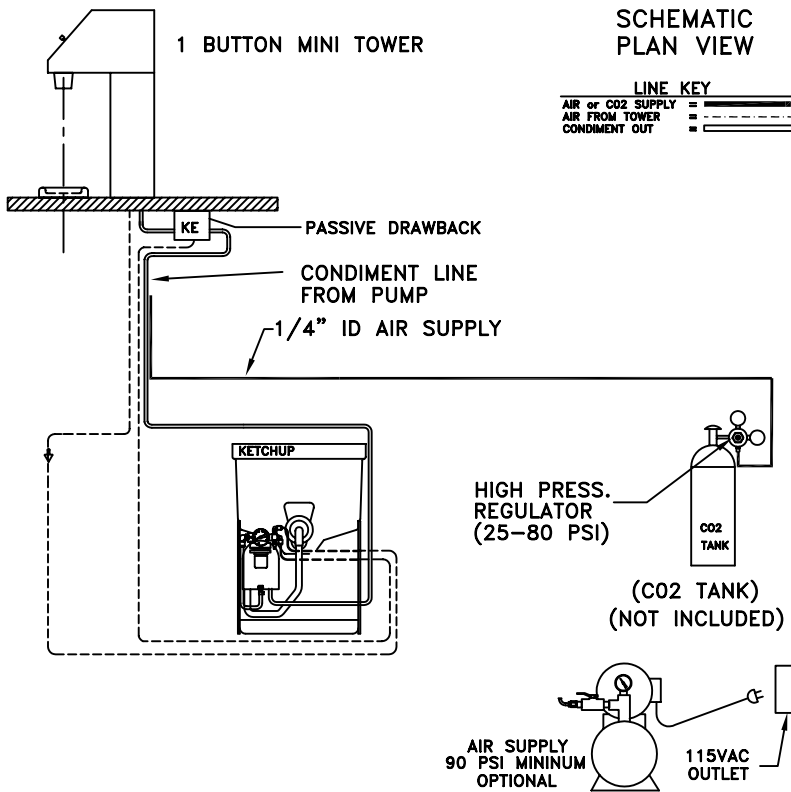
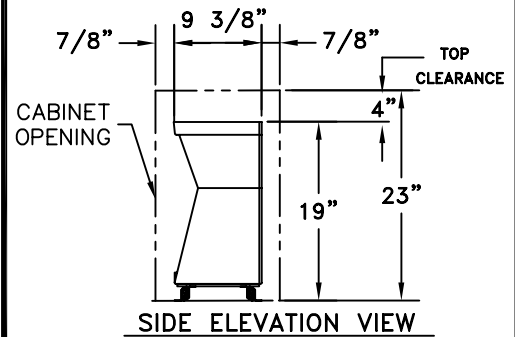
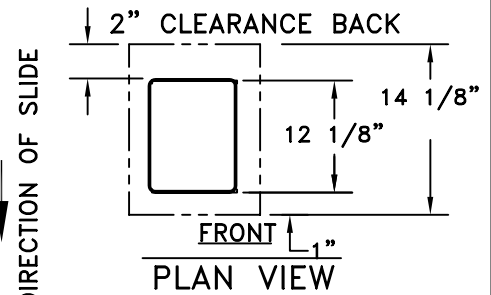

Z:\01\0150021B.DWG / 03-31-2004

# Wunder-Bar Dispensing Systems

AUTOMATIC BAR CONTROLS, INC.  
790 EUBANKS DRIVE  
VACAVILLE, CA 95688

PHONE: (707) 448-5151  
FAX : (707) 448-1521