

MODEL: WB-CD-1-1-ET
 CONDIMENT SYSTEM: 1 STATION WITH
 ONE PRODUCT EURO TOWER DISPENSER

JOB:

ITEM#:



PRODUCT RACK SPECIFICATIONS:

CONSTRUCTION: VACUUM FORMED ACRYLONITRILE BUTADIENE
 STYRENE (A.B.S.) 100# CAPACITY
 EXTRA-HEAVY-DUTY TRAY SLIDES.

CAPACITY: ONE, THREE-GALLON CONDIMENT
 BAG, ONE CONDIMENT PUMP,
 ONE 100# LOW PRESSURE REGULATOR.

DIMENSIONS: 9 3/8" WIDE X 12 1/8" DEEP X 19" HIGH.

INSTALLATION: MINIMUM CABINET REQUIREMENTS
 16 1/8" DEEP X 11 1/8" WIDE X 23" HIGH.

WEIGHT: 35# (EMPTY)

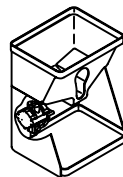

SYSTEM FEATURES:

- FULLY FACTORY ASSEMBLED AND WET-CHECKED NON-PORTION CONTROL CONDIMENT EURO TOWER. SIMPLE CONNECTION OF SYSTEM TO TOWER DISPENSER TO COMPLETE FINAL INSTALLATION.
- BUILT-IN CONDIMENT SPILL CONTAINMENT RIM AROUND PERIMETER OF BASE.
- RACK FULLY EXTENDS FOR EASY RE-LOADING OF BAGS.
- 8' OF 1/4" I.D. PRODUCT TUBING PROVIDED PER CONDIMENT FOR KETCHUP, MUSTARD OR SAUCE. 8' OF 3/8" ID PRODUCT TUBING PROVIDED FOR MAYONNAISE. PLEASE SPECIFY PRODUCTS WHEN ORDERING.
- EXCLUSIVE PASSIVE DRAWBACK VALVE PREVENTS CONDIMENT DRIP BETWEEN DISPENSES. ONE PASSIVE DRAWBACK VALVE INCLUDED PER CONDIMENT PRODUCT.
- ONE PRODUCT EURO TOWER CONDIMENT DISPENSER. ALL MOUNTING HARDWARE INCLUDED.

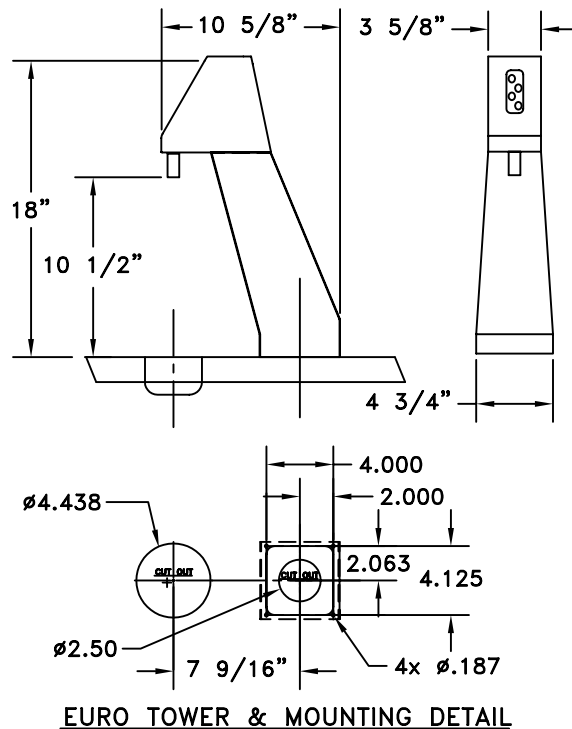
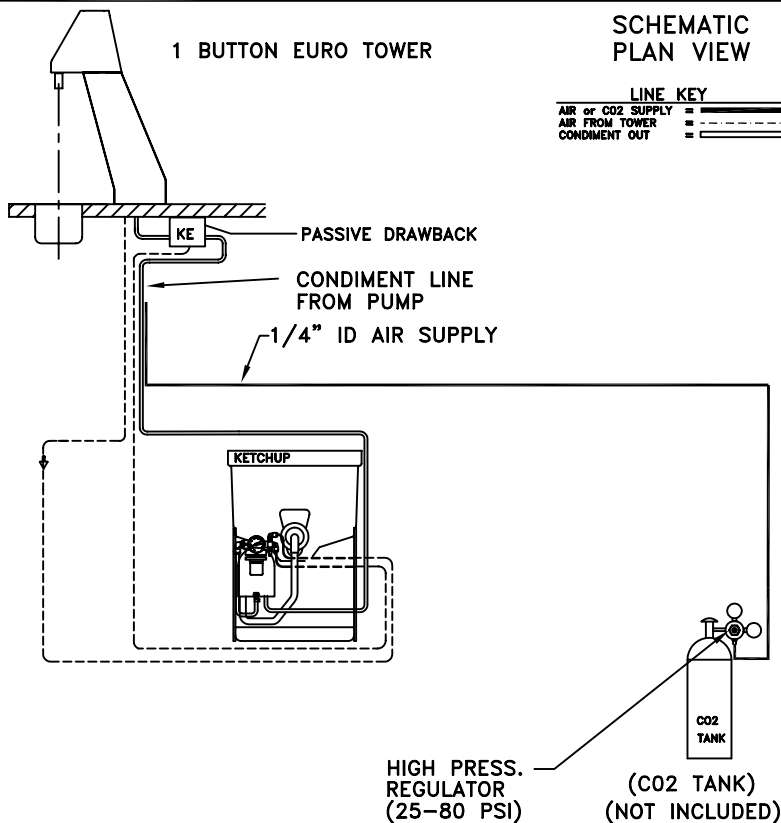
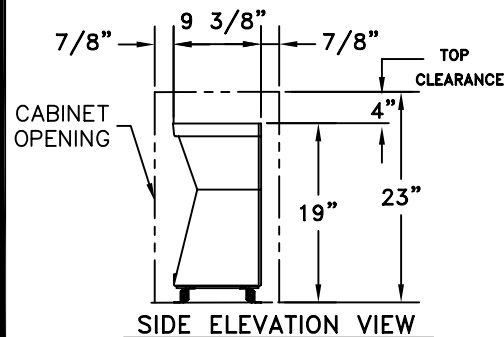
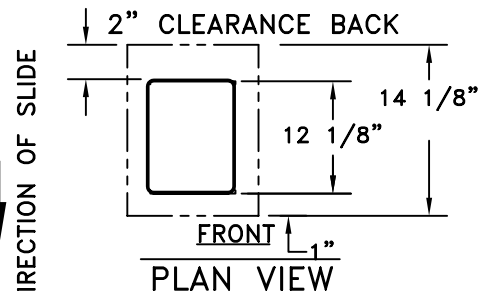

Z:\01\0150173.DWG / 02-26-2004

Wunder-Bar Dispensing Systems

AUTOMATIC BAR CONTROLS, INC.
 790 EUBANKS DRIVE
 VACAVILLE, CA 95688

PHONE: (707) 448-5151
 FAX : (707) 448-1521