

MODEL: WB-CD-2-3-(X)*-RCT-R

2 PRODUCT PARTICULATE COUNTER TOP TOWER:

WITH 3 GALLON BAG HOLDER

* SEE SPECIFICATION NOTES FOR (X)

JOB:

ITEM#:

PRODUCT SPECIFICATIONS:

(X) TOWER FINISH: SS = STAINLESS STEEL
 P = PAINTED * = COLOR: R = RED
 BL = BLACK G = GREEN
 O = ORANGE Y = YELLOW
 P = PURPLE B = BLUE
 W = WHITE BR = BROWN

CAPACITY: TWO 3-GALLON BAG-IN-BOX

DIMENSIONS: 6-13/16" WIDE X 11-3/8" DEEP X 9" HIGH

WEIGHT: 10 LBS. (EMPTY)

* ONE BAG-IN-BOX CONNECTOR INCLUDED PER PRODUCT.
(WUNDER-BAR 18mm CRYOVAC ADAPTER)

SYSTEM FEATURES:

- IN PLACE CLEANABLE
- STAINLESS STEEL CONSTRUCTION
- 3 GALLON PRODUCT HOLDER BELOW COUNTER
- COMPACT TOWER WITH DRIP PAN
- NO ELECTRICITY OR PROPELLANT REQUIRED
- 3/4 OZ NOMINAL POUR SIZE PER FULL PUMP STROKE

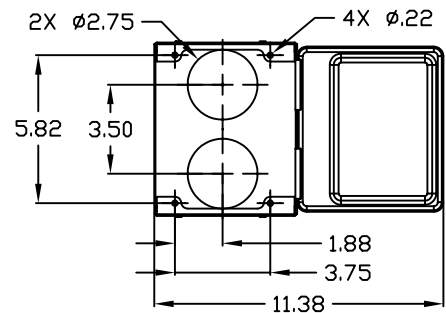
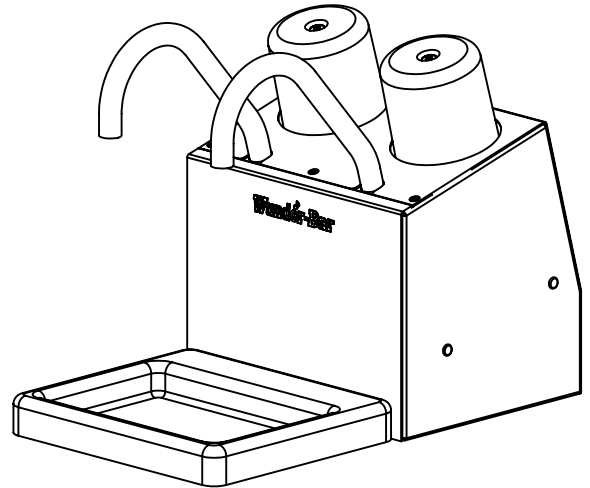

MOUNTING DETAIL:

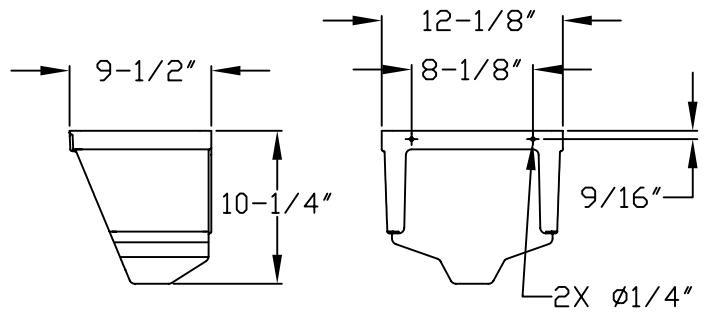
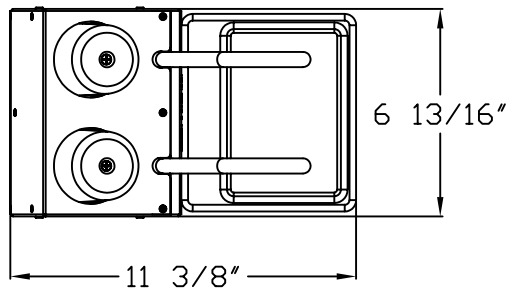

3 GALLON BAG HOLDER

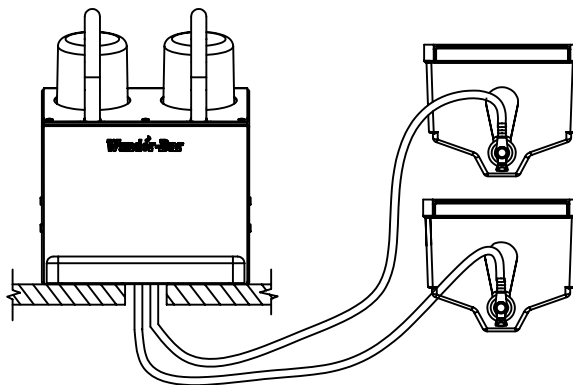
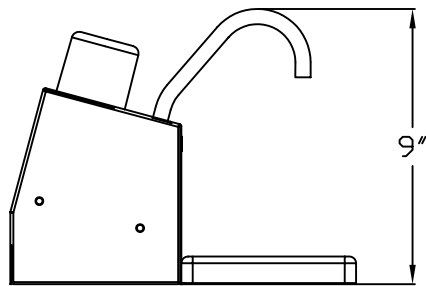

0150249.DWG / 08-23-2004

Wunder-Bar

Dispensing Systems

AUTOMATIC BAR CONTROLS, INC.
790 EUBANKS DRIVE
VACAVILLE, CA 95688

PHONE: (707) 448-5151
FAX : (707) 448-1521