

JOB:

ITEM#:

ELECTRICAL REQUIREMENTS

120V, 1 PHASE, 50/60Hz, 15 AMP DEDICATED
GROUND CIRCUIT

ELECTRICAL SPECIFICATIONS

UL LISTED POWER SUPPLY WITH SIX FOOT CORD WITH
3 PRONG GROUNDED PLUG, 120 VAC, 1 PHASE,
2 AMP, 50/60Hz

MINI 24 BOTTLE LIQUOR RACK

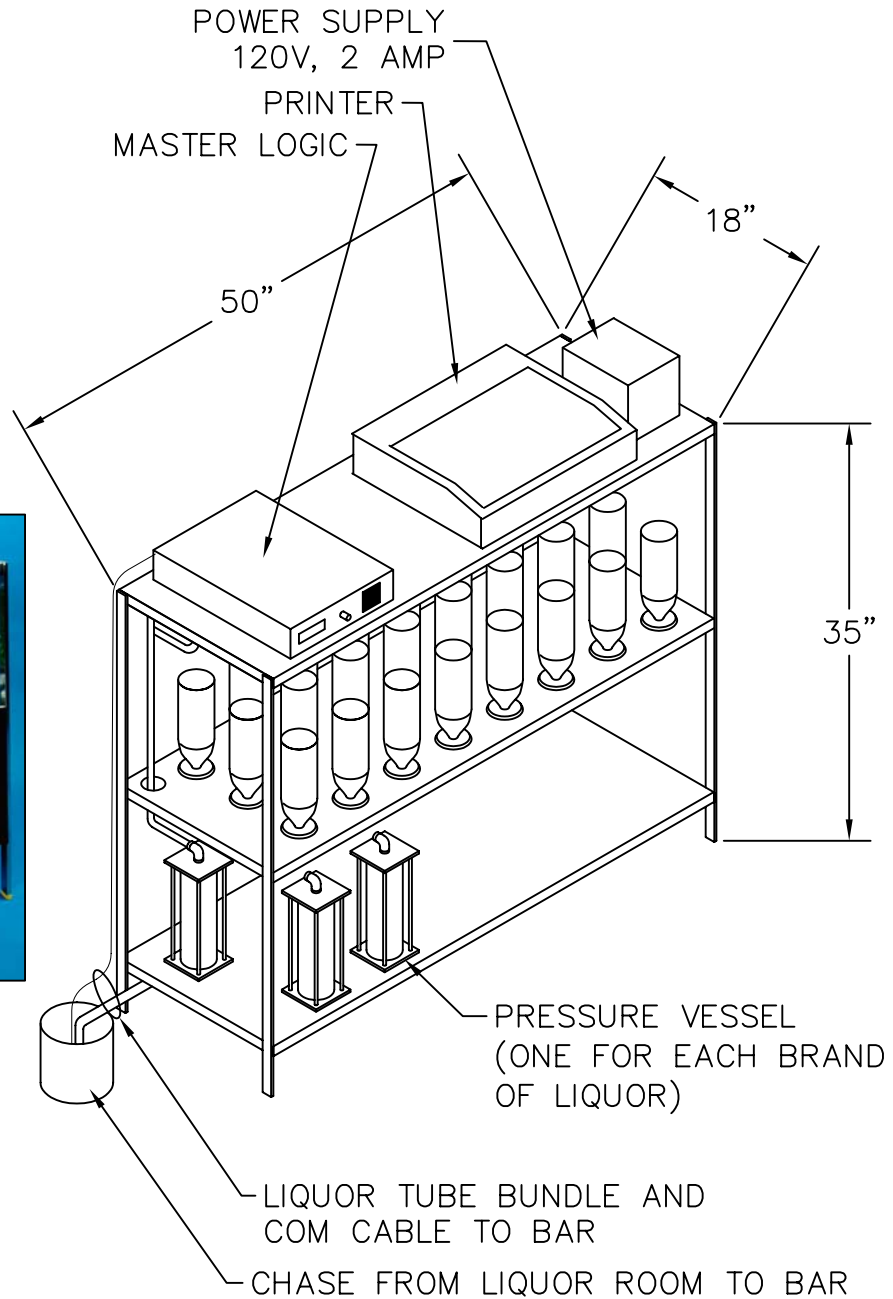

(LOCATED IN LIQUOR ROOM)

AUTOMATIC BAR CONTROLS, INC.
790 EUBANKS DRIVE
VACAVILLE, CA 95688

PHONE: (707) 448-5151
FAX : (707) 448-1521
WWW.WUNDERBAR.COM